



SAFTKISTE

EN

300 LTE-CONNECTED MOTOR-HOME LIFEPO4 BATTERY WITH DUALBMS®

TECHNICAL SPECIFICATIONS

Rated capacity	300 Ah (3,9 kWh)
Nominal voltage	12 V
Charging voltage	14,2 - 14,6 V
Max. charging current	200 A (2,5 kW)
Standard discharge current	200 A (2,5 kW)
Peak discharge current	230 A (3,0 kW) for 60 Sek. at 35°C
Self-discharge	3 to 16 Ah plus 3% of current capacity / month
Cascadability	Switchable: parallel and serial (to 24 V)
Battery computer	Integrated (smart-forecast energy monitor)
Bluetooth	Integrated (BLE 5.2)
LTE	Integrated (10 years, renewable)
Cell heating	Integrated (fully automatic)
Balancer	Integrated (inter-battery-balancing at 24 V)
Shunt	Integrated (detection threshold ~0,1 A)
Main switch	Integrated (PowerMOSFETs)
Battery terminal	Front or top
Temperature range	-30°C to +65°C
Protection class	IP65
Manufacturer's warranty	5 years
Dimensions (LxWxH)	346 x 296 x 199 mm
Weight	26,5 kg
Goods tariff number	8507 60 00 (country of origin: Germany)
Scope of delivery	Saftkiste, battery terminal adapter set, installation instructions and manual
Accessories (optional)	Vehicle mount Ducato, Transit or Universal

MODELS

Battery terminal arrangement:
Front

Article number:
BSL300V0000

GTIN
4270003507738

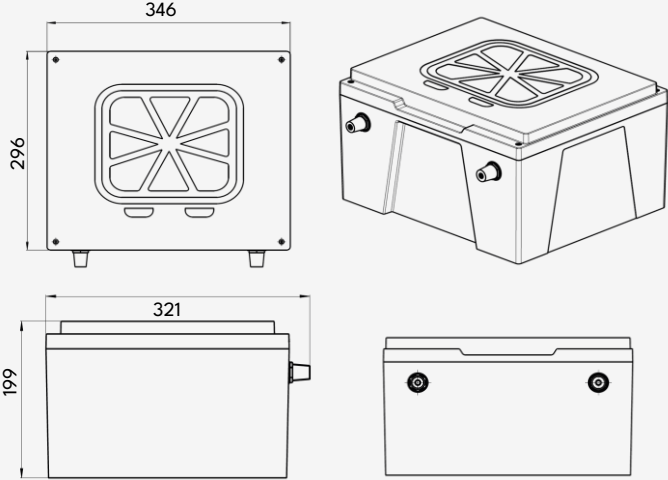

Battery terminal arrangement:
Top

Article number:
BSL300O0000

GTIN
4270003507745

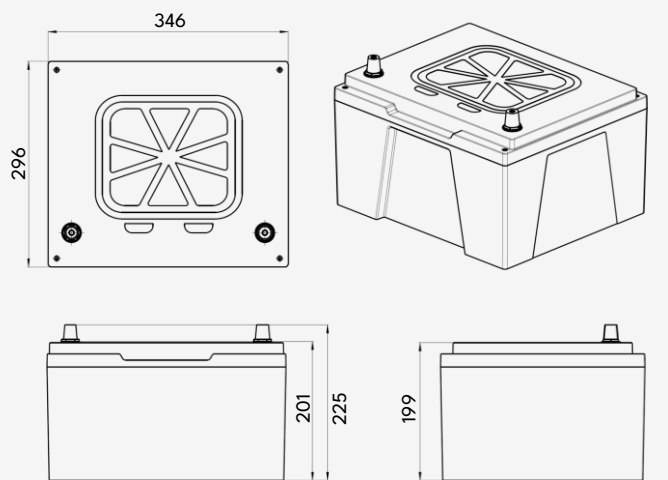

Note: The illustrations show the Saftkiste with screwed-in battery terminal adapters. These are optional and are included in the scope of delivery.