

SLIM SERIES

VITRIFRIGO
COOL AND BEYOND



R290

NATURAL GAS
COMPRESSOR

COMPRESSORE
A GAS NATURALE



H max
365 mm.



SLIM150 CHR

Total volume Capacità totale	140 lt.
Freezer compartment Vano freezer	16 lt.
Net weight Peso netto	37 kg.
Power supply and nominal consumption Alimentazione e consumo nominale	12/24 Vdc 70 W

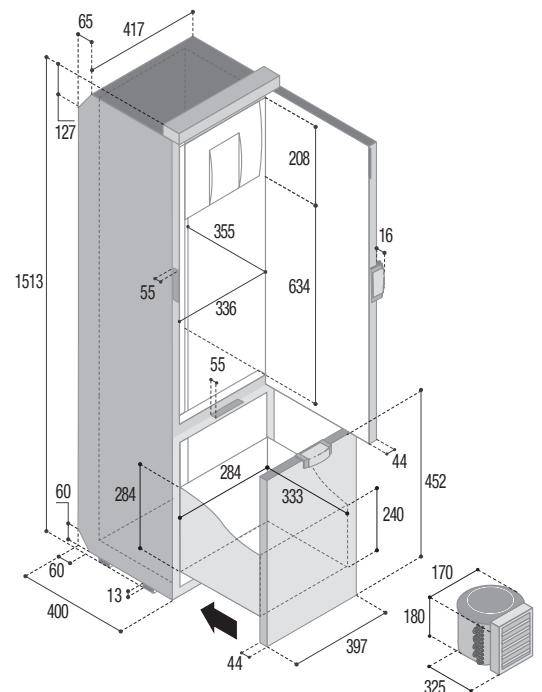
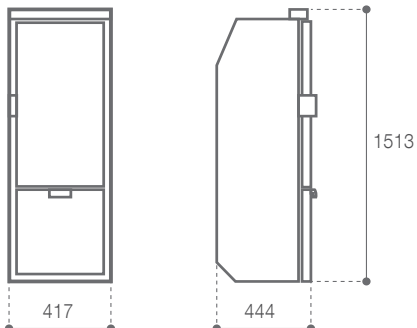

Remotable cooling unit
UNITÀ DI REFRIGERAZIONE REMOTABILE

Up to **1,5**
FINO A **mt.**

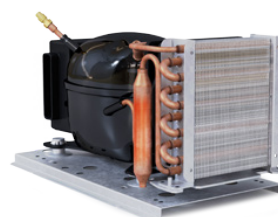



VENT POSITION SYSTEM
SISTEMA VENT POSITION

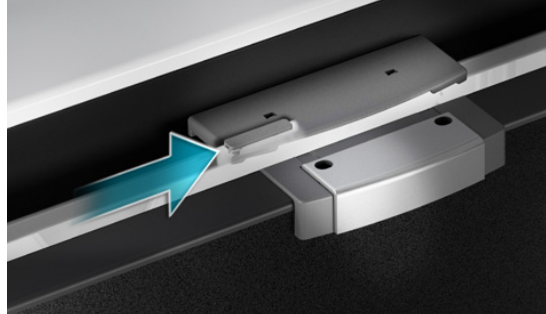

NIGHT MODE

VERY LOW NOISE AND
HIGH ENERGY SAVINGS

SILENZIOSITÀ ASSOLUTA E
RISPARMIO ENERGETICO



TURBO MODE

FAST CHILL SET POINT
TEMPERATURE

RAPIDO
RAGGIUNGIMENTO
DELLA TEMPERATURA



3-STAR FREEZER

FOR FROZEN FOOD
AT -18°C

PER IL CORRETTO
CONGELAMENTO A
-18°C



Finishing panel in two colours: black and light grey
PANNELLO DI FINITURA IN DUE COLORAZIONI: BLACK E LIGHT GREY



Multi-function thermostat with integrated white led lighting
TERMOSTATO MULTIFUNZIONE CON ILLUMINAZIONE A LED BIANCA INTEGRATA

