



# SAFTKISTE

EN

## 100

LTE-CONNECTED MOTOR-HOME  
LIFEPO4 BATTERY WITH DUALBMS®

## TECHNICAL SPECIFICATIONS

Rated capacity	105 Ah (1,35 kWh)
Nominal voltage	12 V
Charging voltage	14,2 - 14,6 V
Max. charging current	100 A (1,3 kW)
Standard discharge current	100 A (1,3 kW)
Peak discharge current	230 A (3,0 kW) for 20 sec. at 35°C
Self-discharge	3 to 16 Ah plus 3% of current capacity / month
Cascadability	Switchable: parallel and serial (to 24 V)
Battery computer	Integrated (smart-forecast energy monitor )
Bluetooth	Integrated (BLE 5.2)
LTE	Integrated (10 years, renewable)
Cell heating	Integrated (fully automatic)
Balancer	Integrated (inter-battery-balancing at 24 V)
Shunt	Integrated (detection threshold ~0,1 A)
Main switch	Integrated (PowerMOSFETs)
Battery terminal	On top
Temperature range	-30°C to +65°C
Protection class	IP65
Manufacturer's warranty	5 years
Dimensions (LxWxH)	244 x 176 x 190 mm
Weight	10,9 kg
Goods tariff number	8507 60 00 (country of origin: Germany)
Scope of delivery	Saftkiste, installation instructions and manual
Accessories (optional)	-

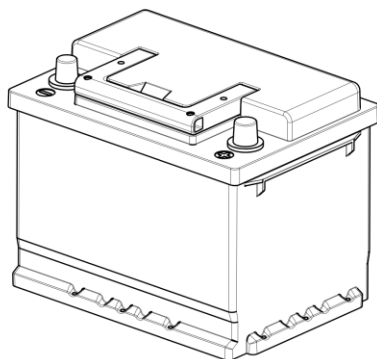
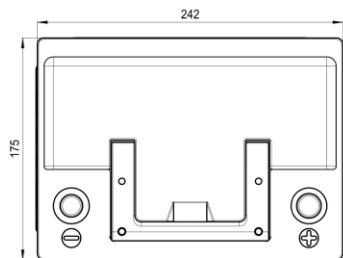
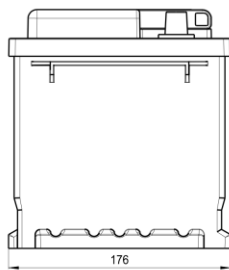
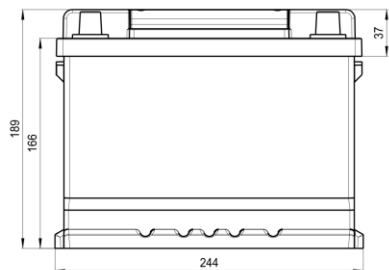

Article number  
BSL10000000

GTIN  
4270003507776