

TOP DRIVE SYSTEM Ref. :
4075510A - 4075519A



www.topdrivesystem.com

Sospensione pneumatica integrativa per :
Rear integrative pneumatic suspension for :

FIAT Ducato X 250
CITROËN Jumper X 250
PEUGEOT Boxer X 250

Dal / Since : 2006

N° OMOLOGAZIONE / HOMOLOGATION N° : TU-026617-B0-436



ISTRUZIONI DI MONTAGGIO / INSTALLATION INSTRUCTIONS

CONTENUTO DELLA CONFEZIONE / PACKAGE CONTENT



Sospensione destra / sinistra (2x)
Right / Left suspension (2x)

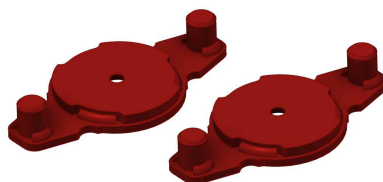

Piastre di ancoraggio (2X)
Locking plates (2X)



Vite M10 (2X)
M10 screw (2X)



Vite bombata M8 (4X)
M8 round screw (4X)



Passacavo (2X)
Grommet (2X)



Rondelle Ø8x16 (4X)
Washers Ø8x16 (4X)

KIT MINUTERIA / SMALL HARDWARE KIT

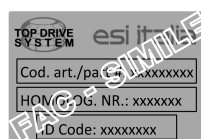

SOSPENSIONI PNEUMATICHE INTEGRATIVE
INTEGRATIVE PNEUMATIC SUSPENSIONS
Pressione sospensioni pneumatiche
Air suspensions pressure
Pression des Suspensions à air
Luftfederungsdruck



Etichetta prodotto (1X)
Product stick (1X)

Etichetta pressioni (1X)
Pressure stick (1X)

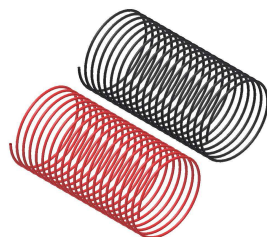

KIT TUBO RILSAN composto da:

- Tubo rosso (6m);
- Tubo nero (6m).

RILSAN KIT PIPE composed by:

- Red pipe (6m)
- Black Pipe (6m)



KIT "TOP DRIVE CONTROL"
preassemblato
Preassembled
"TOP DRIVE CONTROL" KIT



KIT di fissaggio composto da:
• Fascetta in plastica (20x)

Clips kit Composed by:
• Plastic clips (20x)



Istruzioni impianto
pneumatico (1x)
Pneumatic system
instruction (1x)

LATO SX / LEFT SIDE

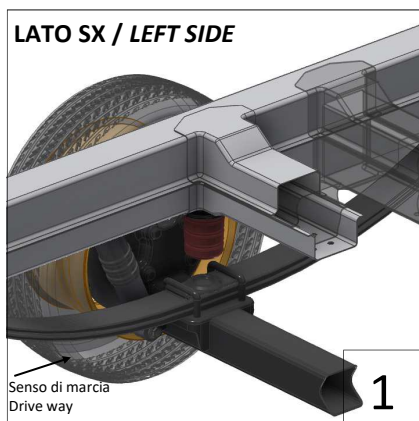

Posizionare il veicolo in modo da operare in **sicurezza** e comodità.

Place the vehicle in a hole or bridge, to operate **SAFE** and comfortably.

LATO SX / LEFT SIDE



Rimuovere il tampone fine corsa e consegnarlo all'utente finale.

Remove rebound pad and give to the end user.

LATO SX / LEFT SIDE

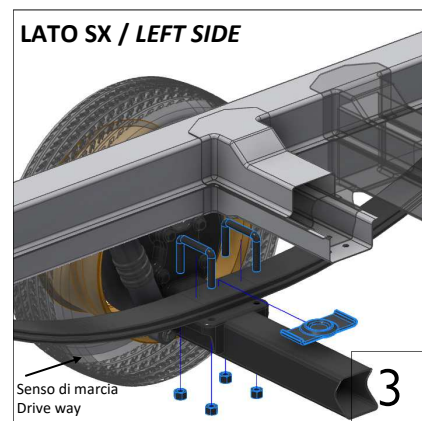

Svitare i cavallotti di fissaggio della balestra, rimuovere la piastra di appoggio originale e consegnarla all'utente finale.

Unscrew leaf spring locking clamps, remove original plate and give to the end user.

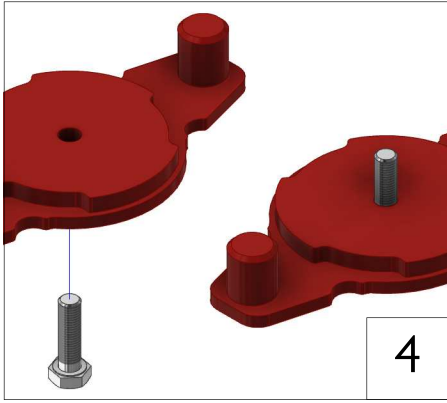

Inserire la vite M10 nella piastra di ancoraggio come mostrato in figura.

Place M10 screw on locking plate as shown in picture.

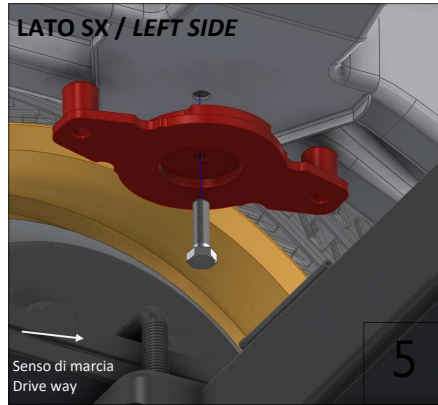

Avvitare la piastra di ancoraggio nel foro del tampone fine corsa con la vite M10, calzando le boccole guida nella scanalatura presente sotto al telaio.

Fasten locking plate in rebound pad hole with M10 screw, fitting lead bushes on chassis slot.



Prima di posizionare la sospensione innestare e fissare il tubo RILSAN dell'impianto pneumatico :

- Tubo rosso per il lato destro
- Tubo nero per il lato sinistro

Before placing air suspension fit RILSAN pipe on pipe fitting :

- Red for right side
- Black for left side.

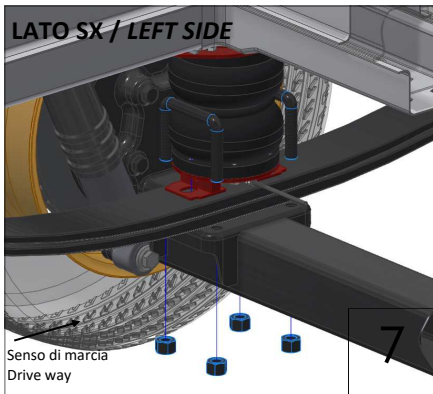

Posizionare la sospensione sull' assale al posto dello zoccolo rimosso in precedenza, fissare utilizzando i dadi ed i cavallotti originali.

Insert suspension on axle in place of original plate, lock with original clamps and nuts previously removed.

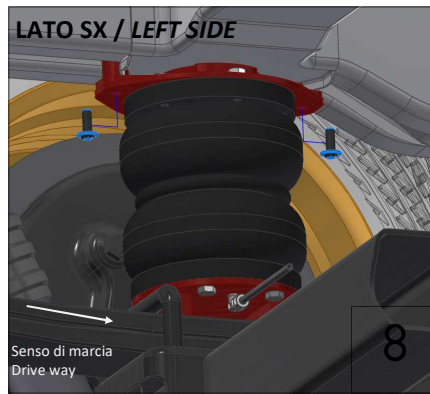

Fissare la sospensione alla piastra di attacco con le viti M8 e le rondelle fornite in dotazione, avvitando le viti nelle boccole guida.

Lock suspension on locking plate with provided M8 screws, lock the screws on the lead bushes .

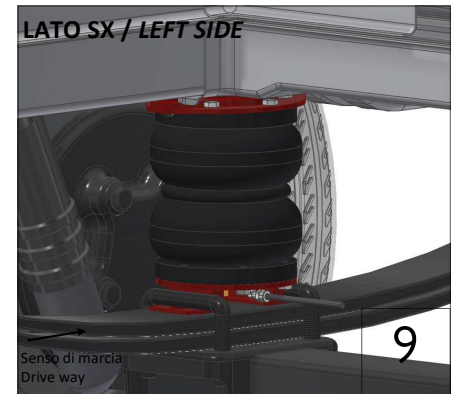

Sospensione correttamente montata. Ripetere le operazioni da 1 a 8 per il lato destro del veicolo.

Suspension correctly mounted. Repeat position from 1 to 8 for the right side of vehicle.



Posizionare l'etichetta delle pressioni di lavoro in cabina in un luogo ben visibile al conducente; posizionare l'etichetta di identificazione prodotto sul fianco interno della portiera lato guida.
N.B.: per l'esecuzione dell'impianto pneumatico attenersi alle istruzioni specifiche non incluse in questo manuale.

Put the work pressure stick in a place visible for the driver, in the cabin; place the product identification sticker on the driver's vehicle door internal side.

NOTE: for the execution of pneumatic system, follow specific instructions not included in this manual. See the "pneumatic system: installation instructions" form (see picture right).

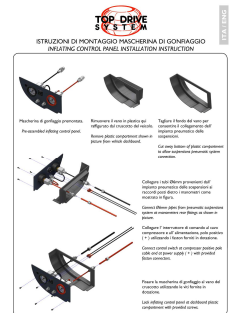
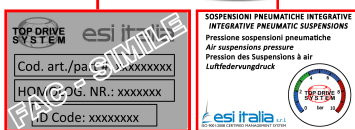

ATTENZIONE: per la realizzazione dell'impianto pneumatico, attenersi alle istruzioni specifiche. Tale impianto infatti può variare a seconda della versione scelta (manuale, autolivellante o elettrico) pertanto le istruzioni per l'impianto pneumatico sono riportate nell'apposito libretto allegato al kit acquistato. In ogni caso serrare i dadi della raccorderia con moderazione, avendo cura di non rimuovere il raccordo nella parte già fissata. Nel caso questo avvenga, rimuovere completamente il raccordo, effettuare una accurata pulizia e fissare nuovamente il raccordo con sigillante da noi consigliato (sigilla filetti, COD. 583500 oppure 5.5000).

IMPORTANTE: NON utilizzare teflon liquido, canapa, vernici ecc.. In caso di problemi e/o informazioni, contattare il nostro ufficio tecnico.

WARNING: For the execution of the pneumatic system, please strictly refer the specific given instructions. In fact, the system may vary according to the chosen version (manual, self levelling or electrical); so than the instructions for the pneumatic system are stated in the apposite handbook enclosed at the purchased kit.

IMPORTANT: do NOT use liquid Teflon®, hemp, paints etc. In case of problem and/or information, contact our technical office. In case you fail to comply at this indications, societies EUROSERVICE s.r.l. and ESI Italia s.r.l. aren't responsible for eventually damages derivatives. For further information contact us.



Piegare con cautela di circa 90° la staffa di supporto del cavo, come mostrato in figura.

Carefully bent the cable support plate, as shown in picture.

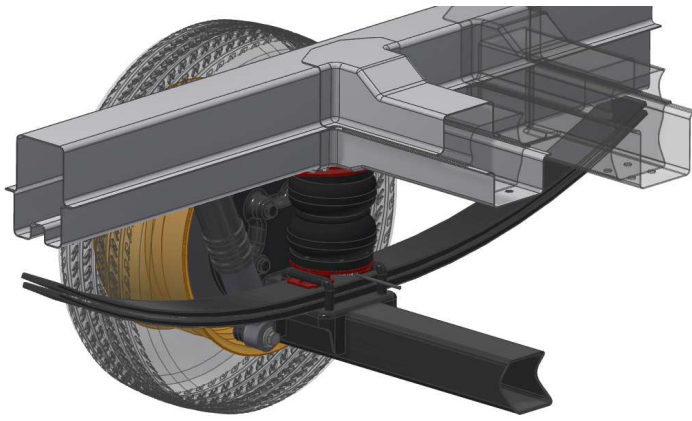

TOP DRIVE SYSTEM

www.topdrivesystem.com

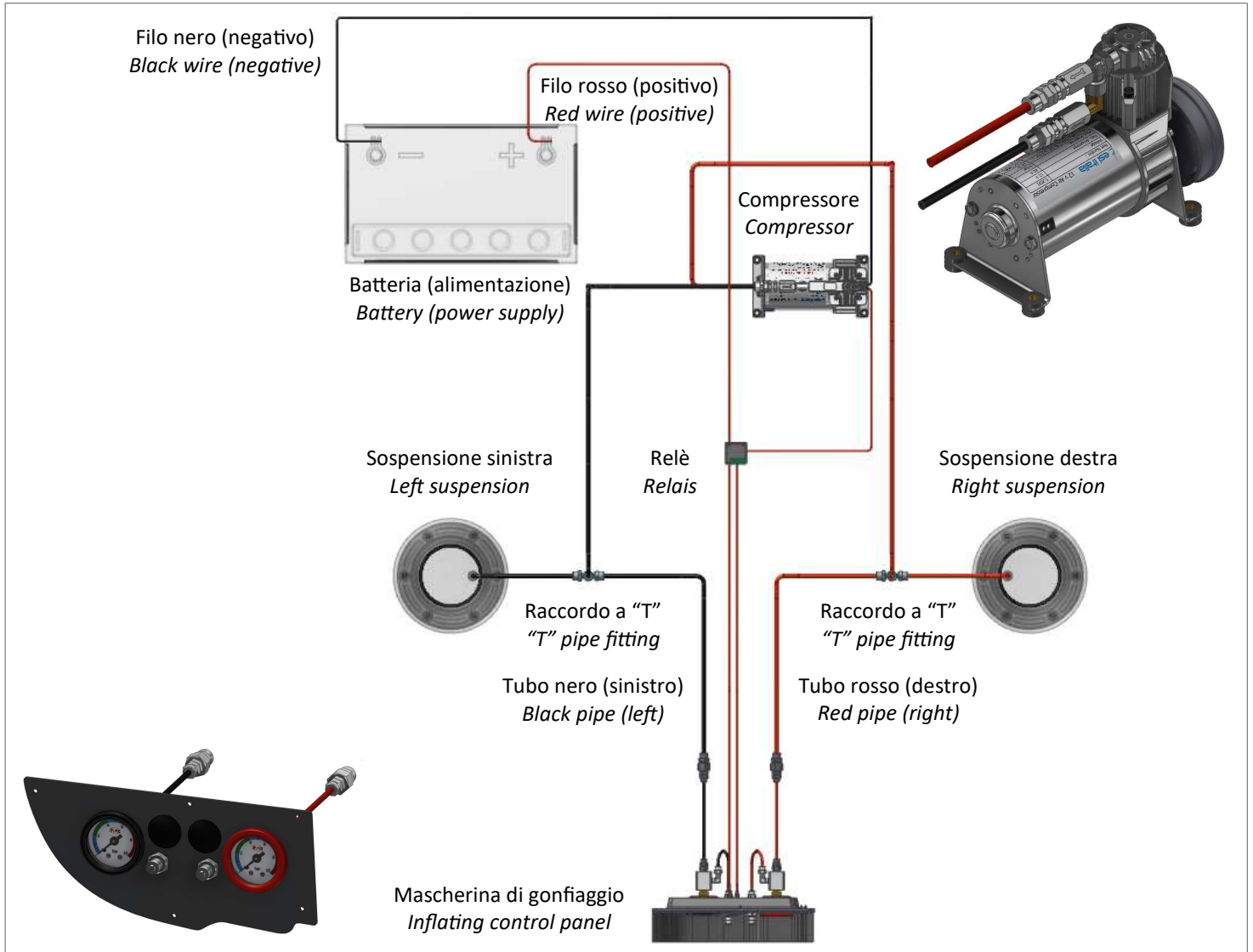

SCHEMA ESEMPLIFICATIVO DI IMPIANTO PNEUMATICO PER SOSPENSIONI INTEGRATIVE
INTEGRATIVE PNEUMATIC SUSPENSIONS SYSTEM EXAMPLE LAYOUT

 **esi italia** S.r.l.
ISO 9001 : 2015 CERTIFIED MANAGEMENT SYSTEM

suspension systems & more

ESI Italia S.r.l.
Strada Fornacino 152
10040 Leini (To) - ITALY
Phone : +39 011 9910838
Fax : +39 (0)11 9910824
info@esitalia.net
www.esitalia.net

Il presente materiale è puramente a scopo illustrativo e può non rispecchiare esattamente i particolari forniti. Il produttore si riserva la facoltà di modificare il contenuto del documento in qualunque momento e senza preavviso.

This leaflet is purely for illustrative purposes and may not reflect correctly the supplied parts. The manufacturer reserves to amend the contents of it whenever necessary and without notice.