

932RE ALARMSYSTEM MIT SIRENE 7746 FÜR VOLKSWAGEN CRAFTER und MAN TGE (2018>)

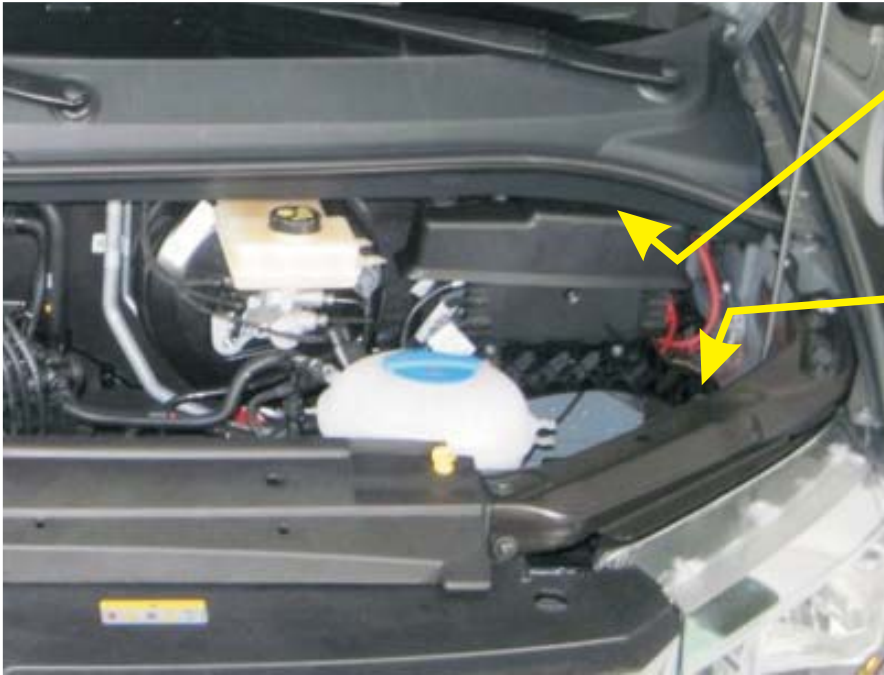

KABELDURCHGANG



SIRENE

Positionieren Sie die Sirene mit den mitgelieferten Muttern und Schrauben an der Halterung. Befestigen Sie die Halterung mit der originalen 10-mm-Schraube am Fahrzeug (siehe Foto oben (→)).

ANSCHLÜSSE

Lokalisieren und entfernen Sie den schwarz-violetten OBD-Stecker aus seinem Sitz unter dem Armaturenbrett auf der Fahrerseite.

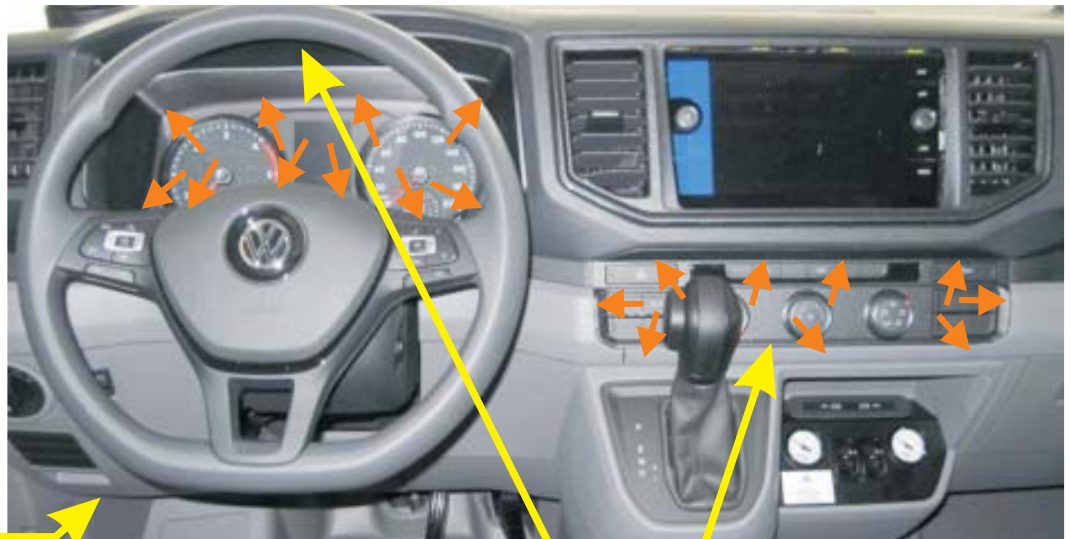

Ausclippen Sie die Verkleidung um das Kombiinstrument und die Klimabedienelemente (Verriegelungslaschen →). Entfernen Sie die 2 Torx 20-Schrauben mit denen die Kunststoffabdeckung des unteren Teils des Kombiinstrument befestigt ist.

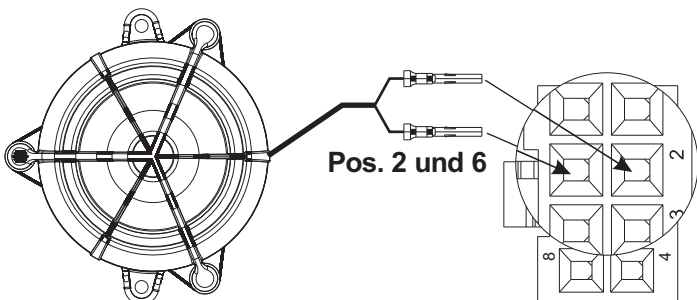

Schließen Sie die Kabel der Sirene an der Steuereinheit an.



Stecken Sie die Kabelbaum Stecker in die entsprechende Buchse am Alarmsteuereinheit.

NEUE GERÄTE HINZUFÜGEN

Nach Abschluss der Verdrahtung, gehen Sie wie folgt vor:

- › Das GRÜNE Kabel (KIT178) des Alarmkabelbaums auf Masse legen (Pos. 15);
- › Innerhalb von 4 Sek. Zündung 4x einschalten und beim viertenmal die Zündung eingeschaltet lassen ("ON-OFF"- "ON-OFF"- "ON-OFF"- "ON");
- › Zur Bestätigung des Eintritts in den Lernmodus die LED leuchtet auf. Um Funksensoren zu koppeln, gehen Sie wie folgt vor:
 - Magnetkontakt: Kontakt und Magnet zusammenbringen und dann auseinander bewegen.
 - Öffnungsmelder: Taste drücken.
- › Ein Piepton bestätigt lernen und die LED schaltet sich für 1 Sek. aus.
- › Schalten Sie den Zündschlüssel. Das Ende des verfahren wird angezeigt indem 2 tiefes signaltone erklingt und die Status-LED erlischt.
- › Das GRÜNE Kabel (KIT178) von der Masse trennen und isolieren.

WARN-LED
Die LED in der unteren Ecke der Windschutzscheibe, Fahrerseite, zu befestigen mit das mitgelieferte doppelseitigen Klebeband.



ULTRASCHALLSENSOREN

Wenn das Ultraschallsensoren am oberen Teil Windschutzscheiben-Innensäulen installiert sind, verlegen Sie jedes Kabel hinter der jeweiligen Säule, um Probleme mit der Kabellänge zu vermeiden.



ELEKTRISCHE ANSCHLÜSSE

Alarmkabel	WEISSER 6-poliger Stecker hinter dem Warnblinkschalter
BLAU	WEISS-GELB (Pos. 4)

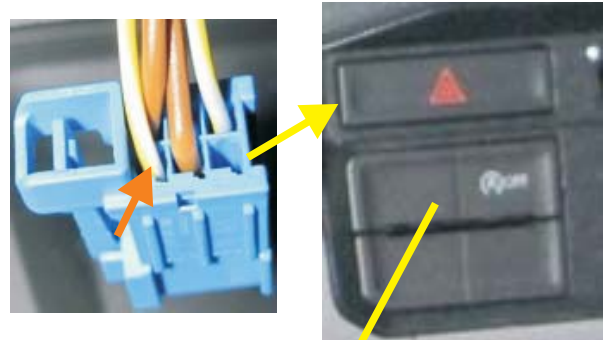

ALARMEINHEIT

Befestigen Sie die Steuereinheit mit dem mitgelieferten doppelseitigen Klebeband auf der linken Seite der Kombiinstrument.

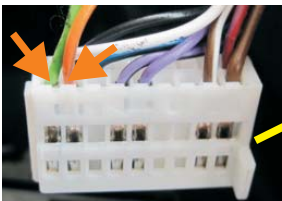

Alarmkabel	SCHWARZ-VIOLETT 18-poliger Stecker hinter dem Kombiinstrument
HELLBLAU-GRAU	ORANGE-GRÜN (Pos. 18)
HELLBLAU	ORANGE-BRAUN (Pos. 17)

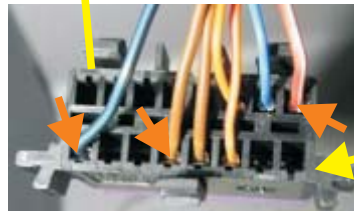

Alarmkabel	SCHWARZ-VIOLETT 16-poliger OBD-Stecker
ROT	ROT-WEISS (Pos. 16)
SCHWARZ	BRAUN (Pos. 4)
GELB	SCHWARZ BLAU (Pos. 1)

HINWEISE: › Der Alarm muss nicht konfiguriert werden, da er bereits werkseitig mit dem CAN-Code 217 eingestellt ist.
› Um den volumetrischen Schutz auszuschließen, drücken Sie die Sperrtaste auf der Originalfernbedienung des Fahrzeugs.

ABSCHLIESSENDE PHASE: Testen Sie das Alarmsystem. Wenn richtig funktionieren, alle Teile wieder montieren; andernfalls, überprüfen Sie alle Verbindungen wurden korrekt hergestellt.

Das BLAUE Kabel im Alarm kabelbaum ist ein negativer Trigger ausgang, der zum Anschluss eines Pagers oder eines GPS-Trackers verwendet werden kann.

SYSTÈME D'ALARME 932RE AVEC SIRÈNE 7746 VOLKSWAGEN CRAFTER et MAN TGE (2018>)

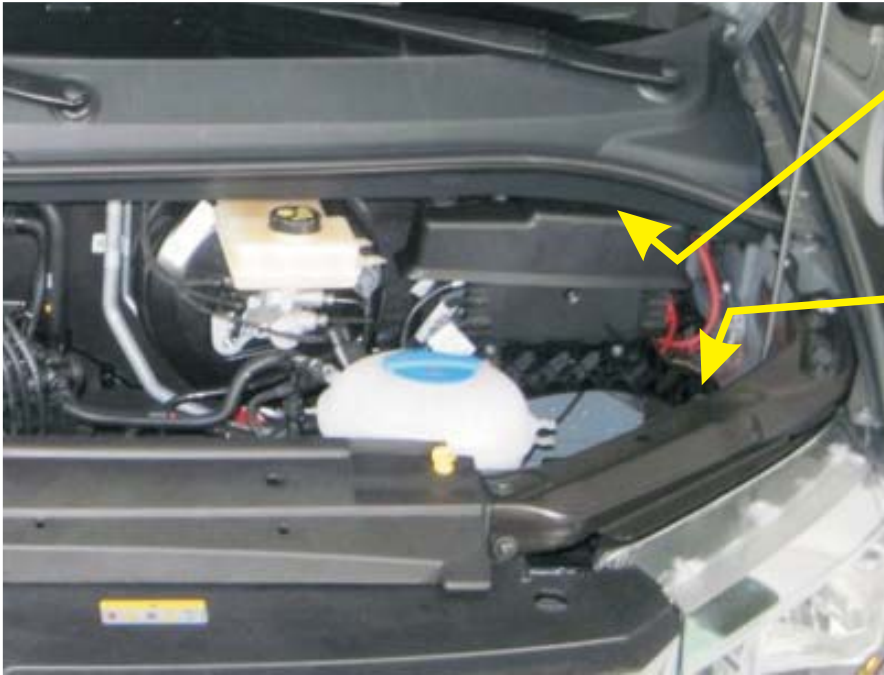

PASSE-CÂBLES



SIRÈNE

Positionner la sirène sur le support de fixation et la sécuriser avec les écrous et les boulons fournis en dotation. Fixer le support au véhicule à l'aide de la vis d'origine de 10mm (→).

DÉMONTAGE ET CONNEXIONS

Déloger le connecteur OBD Noir-Violet de son siège sous le tableau de bord, côté conducteur.

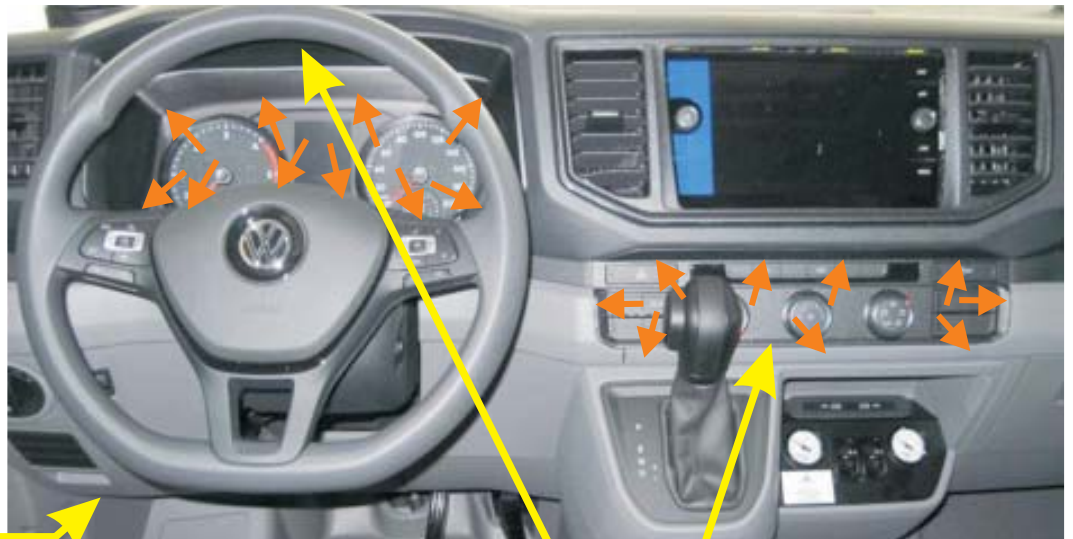

Déclipser les caches du tableau de bord et des commandes de climatisation (languettes de dégagement →).

Enlever les 2 vis Torx 20 qui retiennent le cache inférieur du tableau de bord.

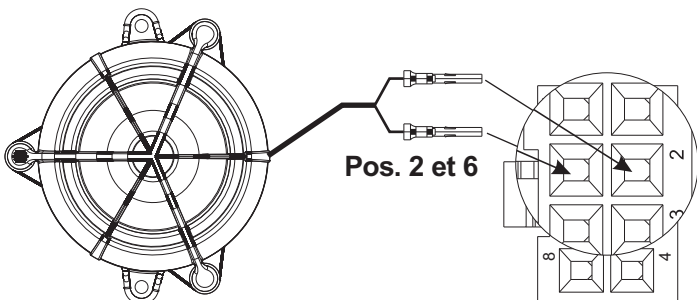

Raccorder les fils de la sirène au boîtier alarme comme indiqué ci-dessus.



Enficher les connecteurs du faisceau dans les prises correspondantes du boîtier alarme.

APPAIRAGE DE NOUVEAUX DISPOSITIFS

Une fois les connexions électriques terminées, procéder comme suit:

- › Mettre à la masse le fil VERT (Pos. 15) du faisceau alarme;
- Dans un délai max. de 4 sec., tourner successivement la clé de contact de la position "Arrêt" à la position "Marche" 4 fois en terminant par la position "Marche" ("ON-OFF"-"ON-OFF"-"ON-OFF"-"ON");
- › La diode s'allume pour confirmer l'entrée en mode appairage.
- › En fonction du dispositif à appairer:
 - Contact magnétique: faire transmettre (approcher et éloigner le contact et l'aimant).
 - Détecteur d'ouverture: appuyer sur le poussoir.
- › Si les dispositifs ont été appris avec succès, la diode s'éteint 1 sec. et la sirène émet 1 Bip de confirmation.
- › Pour sortir du mode appairage, tourner la clé de contact sur "Arrêt": l'opération sera confirmée par 2 Bops et par l'extinction de la diode.
- › Débrancher le fil VERT et l'isoler.

VOYANT D'ALARME

Fixer le voyant (diode d'état) dans le coin gauche, sous le pare-brise, à l'aide de l'adhésif double face fourni en dotation.



CAPSULES ULTRASONS

Une fois installées sur les montants en haut à droite et à gauche du pare-brise, faire courir les fils de chaque capsule derrière le montant respectif en raison de la longueur des fils.



CONNEXIONS ÉLECTRIQUES

Fil alarme	Connecteur BLANC à 6 voies au dos du contacteur "Hazard"
BLEU	BLANC-JAUNE (Pos. 4)

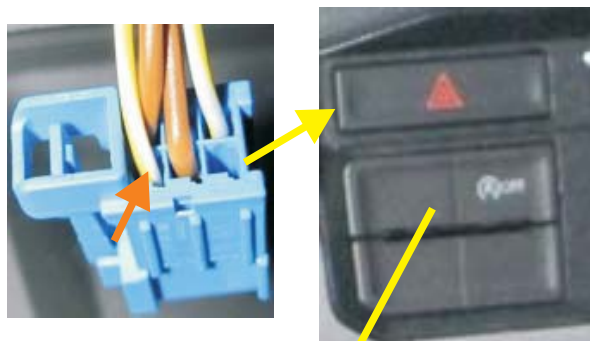

BOÎTIER ALARME

Fixer le boîtier à gauche du tableau de bord à l'aide du ruban adhésif double face inclus dans le kit.

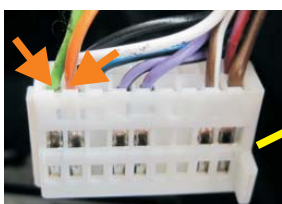

Fil alarme	Connecteur NOIR-VIOLET à 18 voies derrière le tableau de bord
BLEU CLAIR-GRIS	ORANGE-VERT (Pos. 18)
BLEU CLAIR	ORANGE-BRUN (Pos. 17)

Fil alarme	Connecteur OBD NOIR-VIOLET à 16 voies
ROUGE	ROUGE-BLANC (Pos. 16)
NOIR	BRUN (Pos. 4)
JAUNE	NOIR-BLEU (Pos. 1)

NB: › Aucune programmation n'est requise car l'alarme est déjà codifiée à l'usine avec le code CAN 217.
› La protection volumétrique peut être exclue depuis le bouton de verrouillage de la télécommande d'origine.

OPÉRATIONS FINALES: Vérifier le bon fonctionnement du système d'alarme. Si tout fonctionne correctement, remonter les garnitures du tableau de bord, autrement révérifier toutes les connexions effectuées.

Le fil BLEU du faisceau alarme est une sortie négative en condition d'alarme qui sert à raccorder un pager ou un traqueur GPS.

SISTEMA D'ALLARME 932RE CON SIRENA 7746 PER VOLKSWAGEN CRAFTER e MAN TGE (2018>)

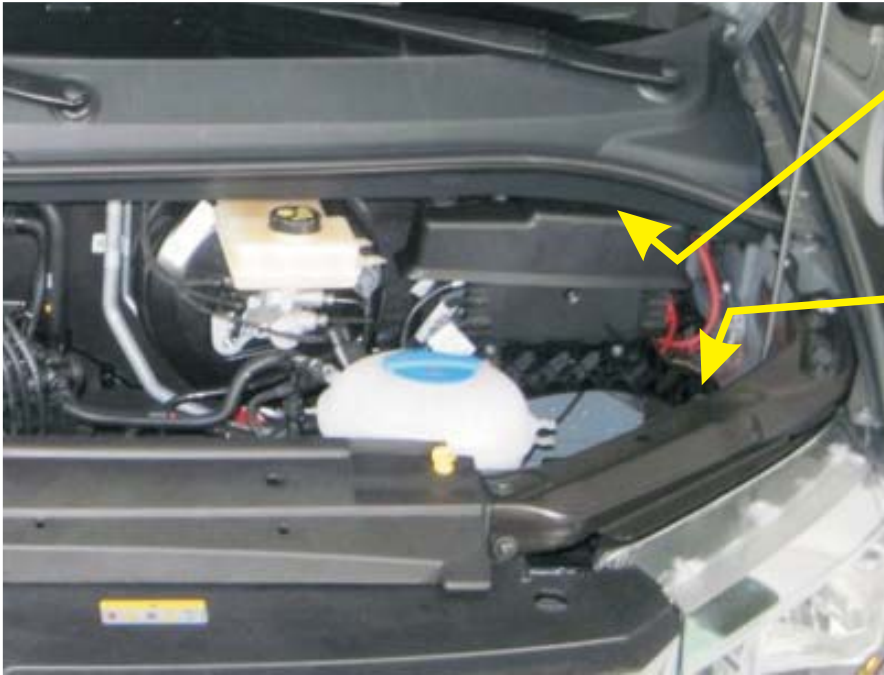

PASSAGGIO CAVI



POSIZIONAMENTO SIRENA

Posizionare la sirena sulla staffa di supporto utilizzando dadi e viti forniti in dotazione. Fissare la staffa al veicolo utilizzando la vite originale da 10mm visibile nella figura qui sopra (→).

POSIZIONAMENTO COMPONENTI E CONNESSIONI ELETTRICHE

Individuare ed estrarre dalla propria sede il connettore OBD di colore Nero-Viola, fissato sotto il cruscotto lato guida.

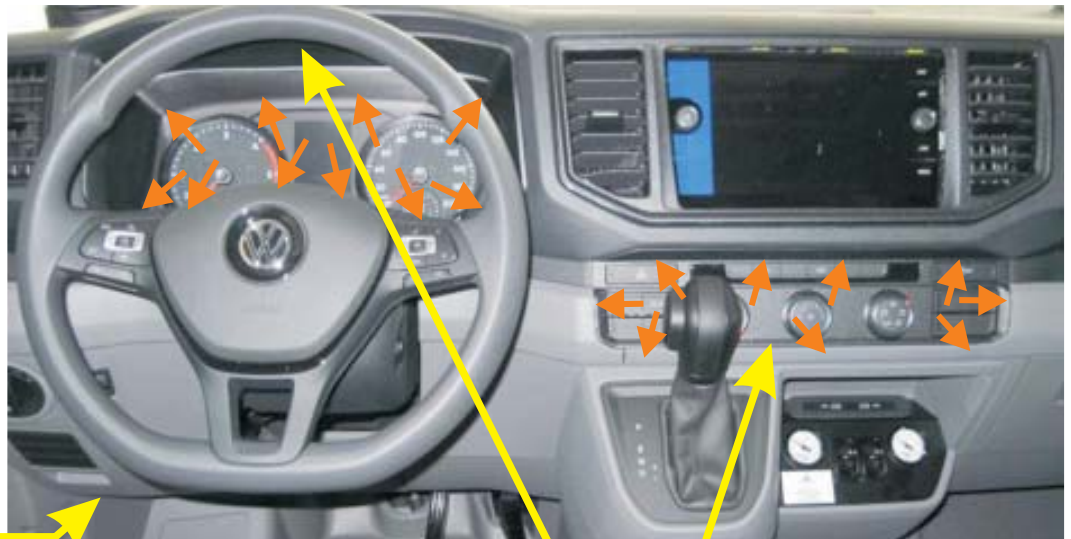

Rimuovere le cornici di quadro strumenti e comandi clima agendo in prossimità delle linguette di bloccaggio fissate a pressione (indicate con →).
Rimuovere le due viti Torx 20 che fissano la parte inferiore del quadro strumenti.

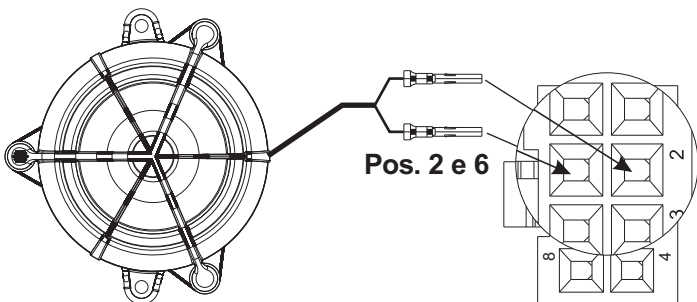

Collegare i cavi sirena alla centrale di allarme.



Inserire i connettori del cablaggio nel corrispondenti connettori della centralina.

PROCEDURA APPRENDIMENTO NUOVI DISPOSITIVI

A collegamenti elettrici ultimati, procedere come segue:

- collegare a massa il filo VERDE (Pos. 15) del cablaggio allarme;
- ruotare la chiave di accensione "ON-OFF"-"ON-OFF"-"ON-OFF"-"ON" in un tempo massimo di 4 secondi;
- la quarta volta lasciare la chiave in posizione "ON": l'accensione del led confermerà l'ingresso nella procedura.
- Far trasmettere il contatto magnetico o premere il pulsante posto sul rilevatore di apertura: lo spegnimento per 1 sec. del Led ed 1 beep confermeranno l'avvenuto apprendimento.
- Per terminare la procedura, ruotare la chiave di accensione in "OFF": 2 Bop e lo spegnimento del led confermeranno l'uscita dalla procedura.
- Scollegare il filo VERDE ed isolarlo.

POSIZIONAMENTO LED SEGNALAZIONE

Fissare il led di segnalazione nella parte bassa del parabrezza, lato guida, utilizzando il biadesivo fornito in dotazione.



INSTALLAZIONE CELLE ULTRASUONI

Se si installano nella parte alta dei montanti parabrezza, occorre stendere il cavo di ogni cella dietro il rispettivo coprimontante, per evitare di avere problemi con la lunghezza dei cavi.



COLLEGAMENTI ELETTRICI

Colore cavo allarme	Connettore BIANCO a 6 vie sul retro del tasto "Hazard"
BLU	BIANCO-GIALLO (Pos. 4)

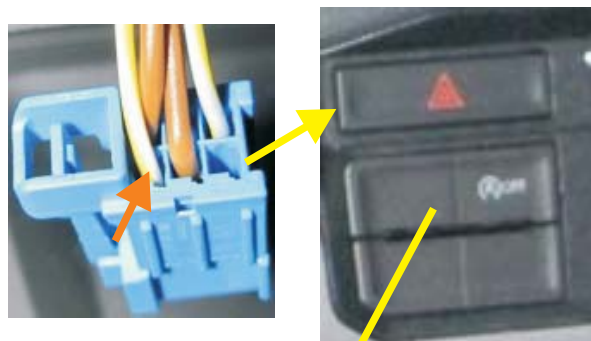

POSIZIONAMENTO CENTRALINA

Fissare la centralina alla sinistra del quadro strumenti, utilizzando il biadesivo fornito in dotazione.

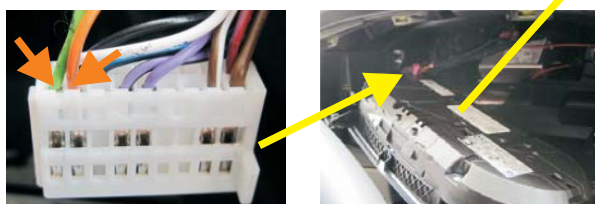

Colore cavo allarme	Connettore NERO-VIOLA 18 vie sul retro del quadro strumenti
AZZURRO-GRIGIO	ARANCIO-VERDE (Pos. 18)
AZZURRO	ARANCIO-MARRONE (Pos. 17)



Colore cavo allarme	Connettore diagnosi (OBD) NERO-VIOLA a 16 vie
ROSSO	ROSSO-BIANCO (Pos. 16)
NERO	MARRONE (Pos. 4)
GIALLO	NERO-BLU (Pos. 1)

NOTE: - il sistema è già programmato con il codice Can corretto (217); non è necessaria alcuna programmazione;
- è possibile escludere i sensori volumetrici tramite il tasto di chiusura del radiocomando originale.

OPERAZIONI FINALI: collaudare il funzionamento del sistema di allarme.

Se risulta corretto, ripristinare il fissaggio delle plastiche del cruscotto; in caso contrario, controllare nuovamente i collegamenti effettuati.

Sul cablaggio allarme è presente un filo BLU: è un'uscita negativa in allarme per il collegamento di pager / localizzatore satellitare.

932RE ALARM SYSTEM WITH 7746 SIREN FOR VOLKSWAGEN CRAFTER & MAN TGE (2018>)

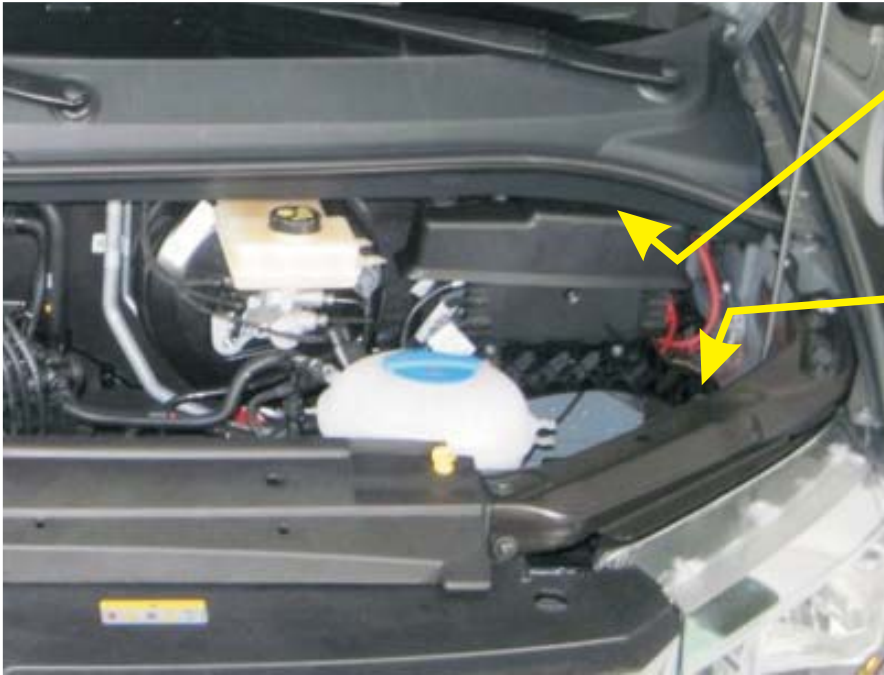

CABLE ROUTING (GROMMET)



SIREN MOUNTING POSITION

- › Attach the siren to the bracket with the supplied nuts and screws.
- › Secure the bracket assembly to the vehicle with the original 10mm screw (→).

PREPARING FOR INSTALLATION

Remove the Black-Violet OBD connector from its seat (located under the driver side dash).

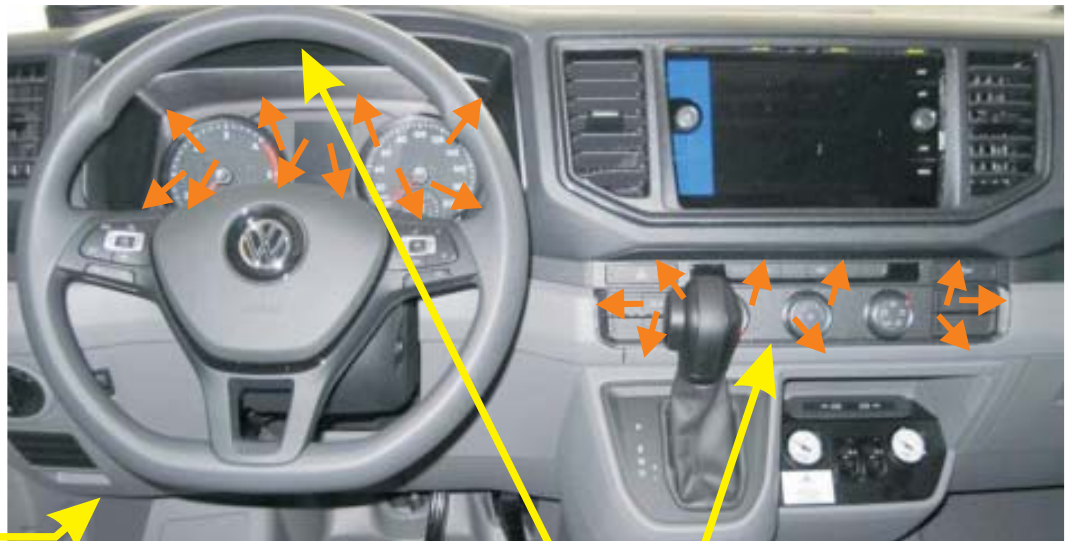

Unclip and remove the trim from around the instrument cluster and climate controls (snap-in clips →).
Remove the 2 Torx 20 screws on the bottom section of the instrument cluster.

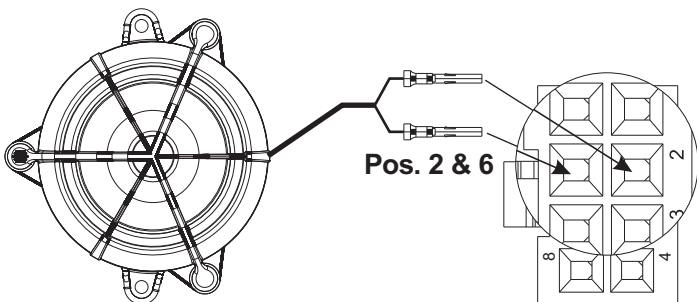

Connect the siren wires to the alarm unit.



Plug the harness connectors into the alarm corresponding sockets.

PAIRING PROCEDURE

After wiring is completed, proceed as follows:

- › Ground the alarm harness GREEN wire (Pos. 15);
- › Cycle ignition key 4 times within 4 sec. ending the cycle with the key in the ON position (“ON-OFF”-“ON-OFF”-“ON-OFF”-“ON”);
- › The LED will power ON to confirm the system is in learn mode.
- › To pair wireless sensors, proceed as follows:
 - Magnetic contact: make it transmit (bring contact and magnet together then move apart);
 - Opening detector: press the button.
- › A Beep will confirm the device has been paired and the LED will power OFF 1 sec.
- › To exit the procedure, turn ignition key OFF: 2 Bops will confirm the operation and the LED will power OFF.
- › Disconnect and insulate the GREEN wire.

STATUS LED

Use the supplied double-sided tape to adhesively mount the LED to the bottom left-hand corner of the windshield.



ELECTRICAL CONNECTIONS

Alarm wire	WHITE 6-pin connector behind the Hazard switch
BLUE	WHITE-YELLOW (Pos. 4)

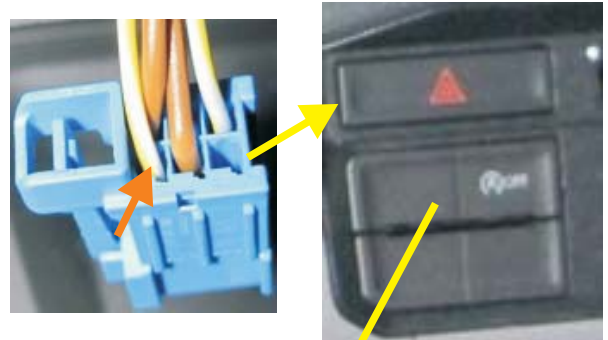

ULTRASONIC CELLS

If installed in the top part of the windshield internal pillars, run each wire behind the respective pillar to avoid cable-length issues.



ALARM UNIT

Use the supplied double-sided tape to attach the unit on the left hand side of the instrument cluster.

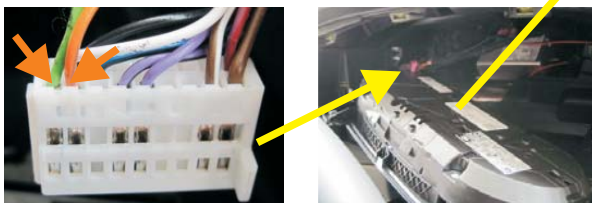

Alarm wire	BLACK-VIOLET 18-pin connector behind the instrument cluster
LIGHT BLUE-GREY	ORANGE-GREEN (Pos. 18)
LIGHT BLUE	ORANGE-BORWN (Pos. 17)

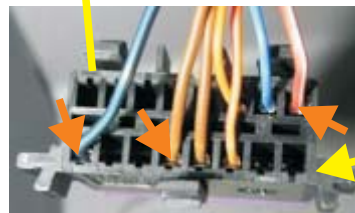

Alarm wire	BLACK-VIOLET 16-pin OBD connector
RED	RED-WHITE (Pos. 16)
BLACK	BROWN (Pos. 4)
YELLOW	BLACK-BLUE (Pos. 1)

NB: › The alarm does not need to be configured as it is already factory set with CAN code 217.

› To exclude volumetric protection, press the lock button on the vehicle original remote control.

FINAL OPERATIONS: Test the alarm system. If it works properly, remount the dash panels otherwise double check all connections to make sure they have been made correctly.

The BLUE wire in the alarm harness is a negative trigger output which can be used to connect a pager or a GPS tracker.